

INSTRUCTION MANUAL

QLD Schools / TAFE - BG-8 Bench Grinder (415V) 200mm



K8820

GRINDER COMBINATION MACHINE

Instruction Manual

Before using be sure to read this manual

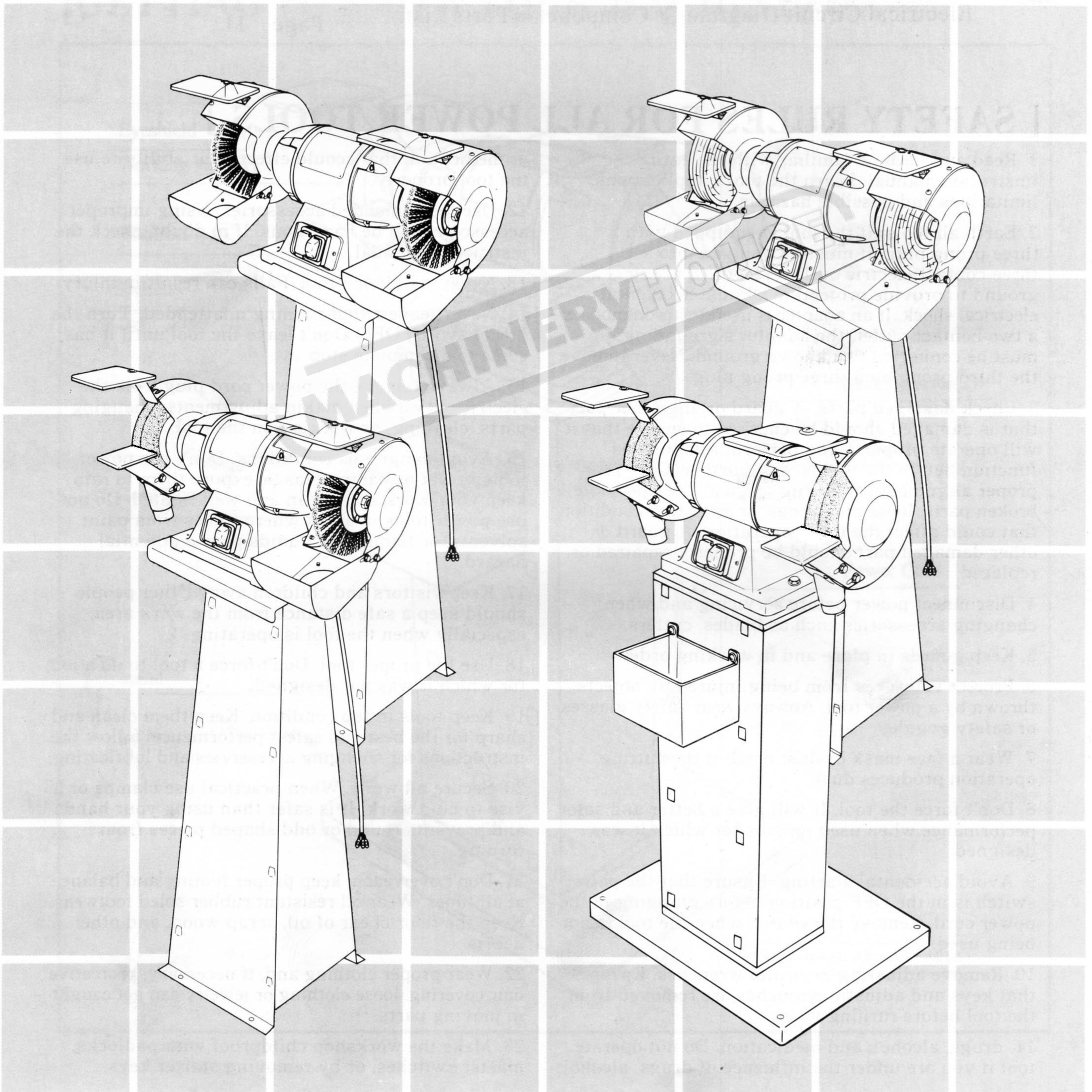

Technical Data for GR Type	Page 1
Technical Data for CN Type	Page 2
Technical Data for PR Type	Page 3
Unpacking and Checking List	Page 4
Replacement of Wheel & Adjustment of Wheel Balance	Page 5
Exploded View	Page 6,7
About Workstand	Page 8
Dust Collection Device	Page 9
Important Notice for CE	Page 10
Electrical Circuit Diagram & Components Parts List.....	Page 11

[SAFETY RULES FOR ALL POWER TOOLS]

1. Read and become familiar with the entire instruction manual. Learn the tool's applications, limitations and possible hazards.
2. Earth all tools. If the tool is equipped with a three-prong plug, it must be plugged into a three-contact electric outlet. The third prong is a ground to provide protection against accidental electrical shock. If an adapter is used to accommodate a two-contact outlet, the adaptor's grounding lug must be connected to a known ground. Never remove the third prong on a three-prong plug.
3. Check damaged parts. A guard or any other part that is damaged should be checked to ensure that it will operate properly and perform its intended function before the tool is used further. Check for proper alignment of moving parts and for possible broken parts, loose mountings, or any other condition that could affect the tool's operation. A guard or other damaged part should be properly repaired or replaced.
4. Disconnect power before servicing and when changing accessories such as blades, cutters.
5. Keep guards in place and in working order.
6. Protect your eyes from being injured by objects thrown by a power tool. Always wear safety glasses or safety goggles.
7. Wear a face mask or dust mask if the cutting operation produces dust.
8. Don't force the tool. It will give a better and safer performance when used on jobs for which it was designed.
9. Avoid accidental starting. Ensure that the power switch is in the OFF position before plugging in the power cord. Remove the switch when the tool is not being used.
10. Remove adjusting keys and wrenches. Ensure that keys and adjusting wrenches are removed from the tool before turning it on.
11. drugs, alcohol, and medication. Do not operate tool if you are under the influence of drugs, alcohol, or medication that could effect your ability to use the tool properly.
12. Use recommended accessories. Using improper accessories can be hazardous. If in doubt, check the instruction manual.
13. Never stand on a tool. Falls can result in injury.
14. Never leave a tool running unattended. Turn the power switch OFF. Don't leave the tool until it has come to a complete stop.
15. Always remove the power cord plug from the electric outlet when making adjustments, changing parts, cleaning, or working on the tool.
16. Avoid dangerous conditions. Don't use power tools in wet or damp areas or expose them to rain. Keep your work area clean and well lighted. Do not use power tools in areas where fumes from paint, solvents, or flammable liquids pose a potential hazard.
17. Keep visitors and children away. Other people should keep a safe distance from the work area, especially when the tool is operating.
18. Use the proper tool. Don't force a tool to do a job for which it was not designed.
19. Keep tools in top condition. Keep them clean and sharp for the best and safest performance. Follow the instructions for changing accessories and lubricating.
20. Secure all work. When practical use clamps or a vise to hold work. It is safer than using your hands and prevents round or odd-shaped pieces from turning.
21. Don't overreach. Keep proper footing and balance at all times. Wear oil-resistant rubber-soled footwear. Keep the floor clear of oil, scrap wood, and other debris.
22. Wear proper clothing and, if necessary, protective hair covering. Loose clothing or jewelry can get caught in moving parts.
23. Make the workshop childproof with padlocks, master switches, or by removing starter keys.

[TECHNICAL DATA]

Model	GR831/833	GR1031/1033	GR1031/1033-4P
Grinding Wheel (mm)	200x25x20	250x38x25.4 (RESINOUS)	250x38x25.4
Motor (output kW)	0.30	0.75	0.56
Speed (50hz / rpm)	2850		1420
Dimension (mm)	470x210x275	580x265x350	
Net Weight (kgs)	19.5	47	43

* Dimensional width not includes toolresr.

* Above data is manufacturer's standard specification. It can be produced by customers' special request.

[GETTING TO KNOW YOUR MACHINE]

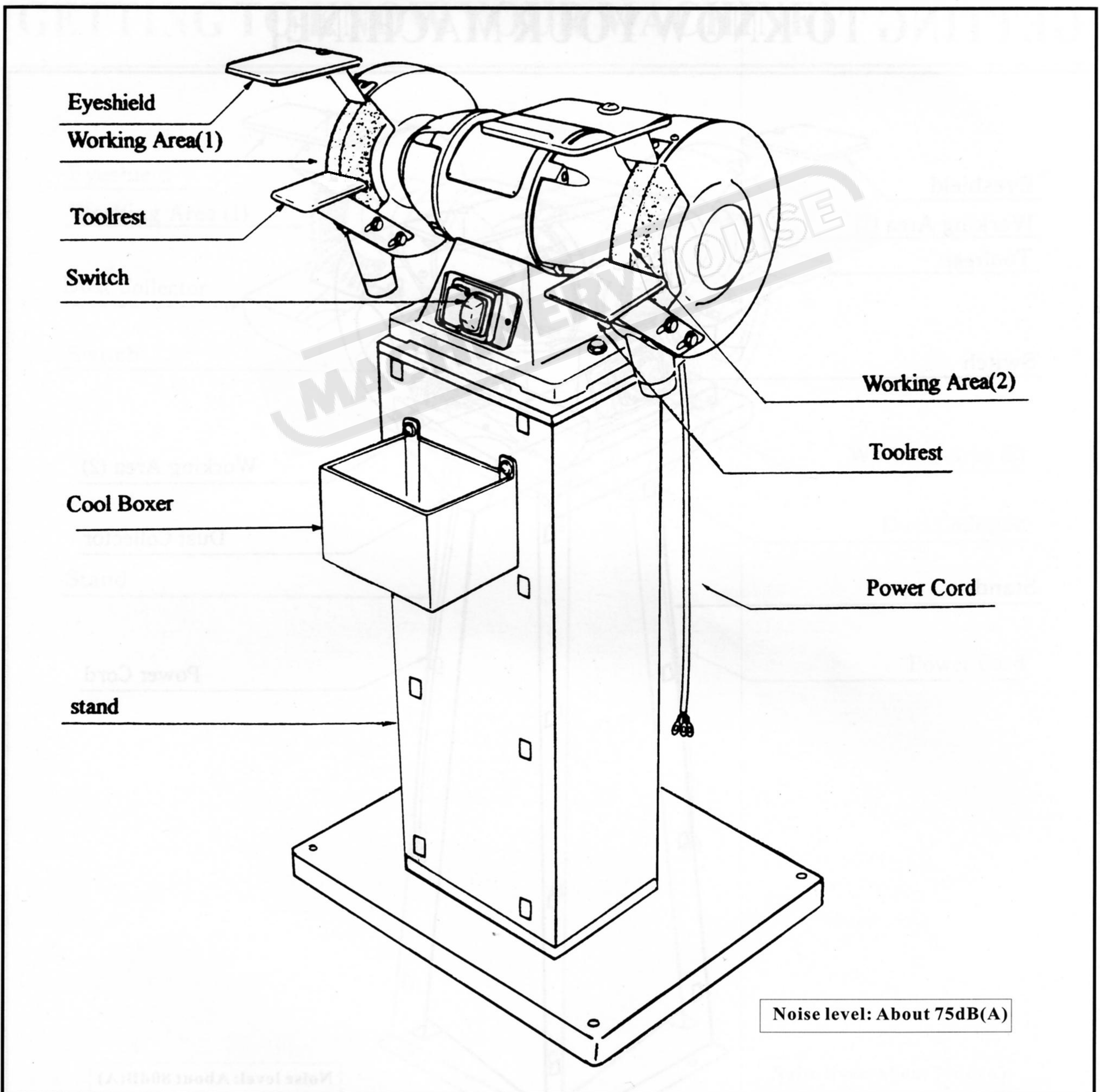

[TECHNICAL DATA]

Model	CN831/833	CN1031/1033
Grinding Wheel (mm)	200x25x20	250x38x25.4 (RESINOUS)
Wire Brush (mm)	200x19x15.88	250x22x25.4
Motor (output kW)	0.30	0.75
Speed (50hz / rpm)	2850	
Dimension (mm)	520x210x275	630x265x350
Net Weight (kgs)	20	44

* Dimensional width not includes toolrest and dust collector.

* Above data is manufacturer's standard specification. It can be produced by customers' special request.

[GETTING TO KNOW YOUR MACHINE]

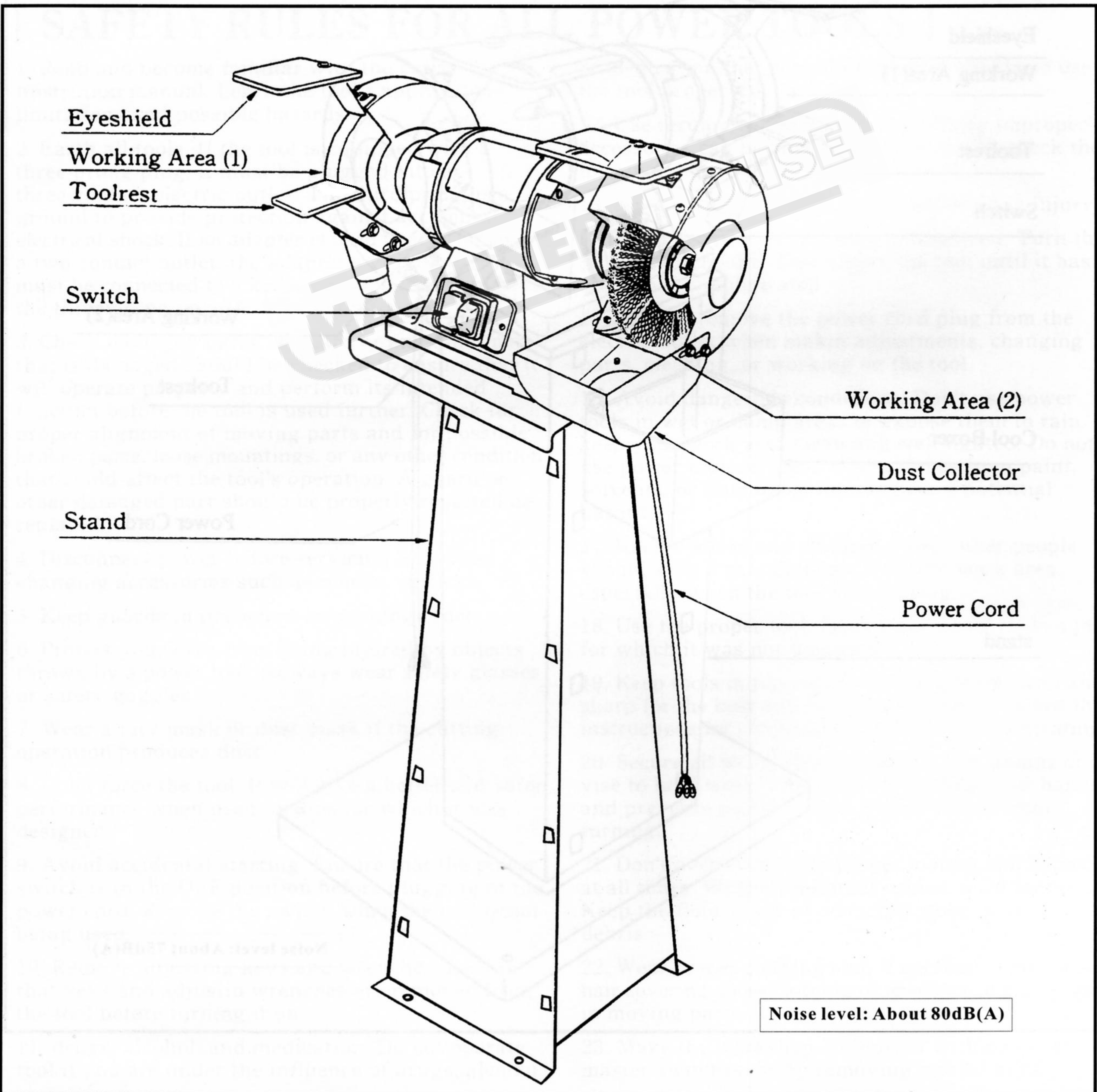

[TECHNICAL DATA]

Model	PR831/833	PR731/733	PR931/933
Wire Brush (mm)	200x19x15.88	N / A	N / A
Mop/Buffer (mm)	N / A	175x19x15.88	225x22x25.4
Motor (output kW)	0.30	0.30	0.56
Speed (50hz / rpm)	2850		
Dimension (mm)	520x210x275	570x200x275	680x255x350
Net Weight (kgs)	20	19.5	39.5

* Dimensional width not includes dust collector.

* Above data is manufacturer's standard specification. It can be produced by customers' special request.

[GETTING TO KNOW YOUR MACHINE]

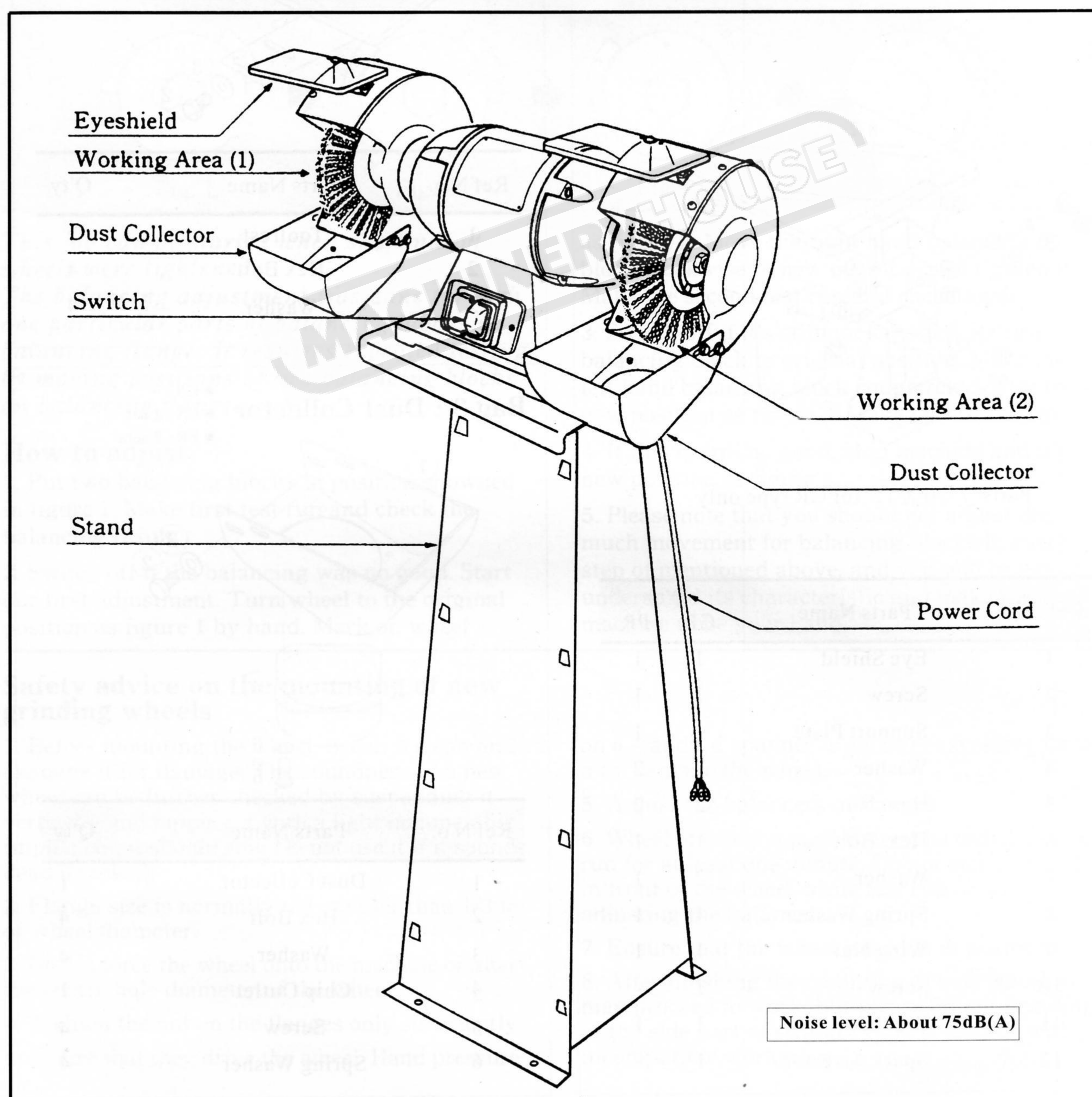

[UNPACKING AND CHECKING LIST]

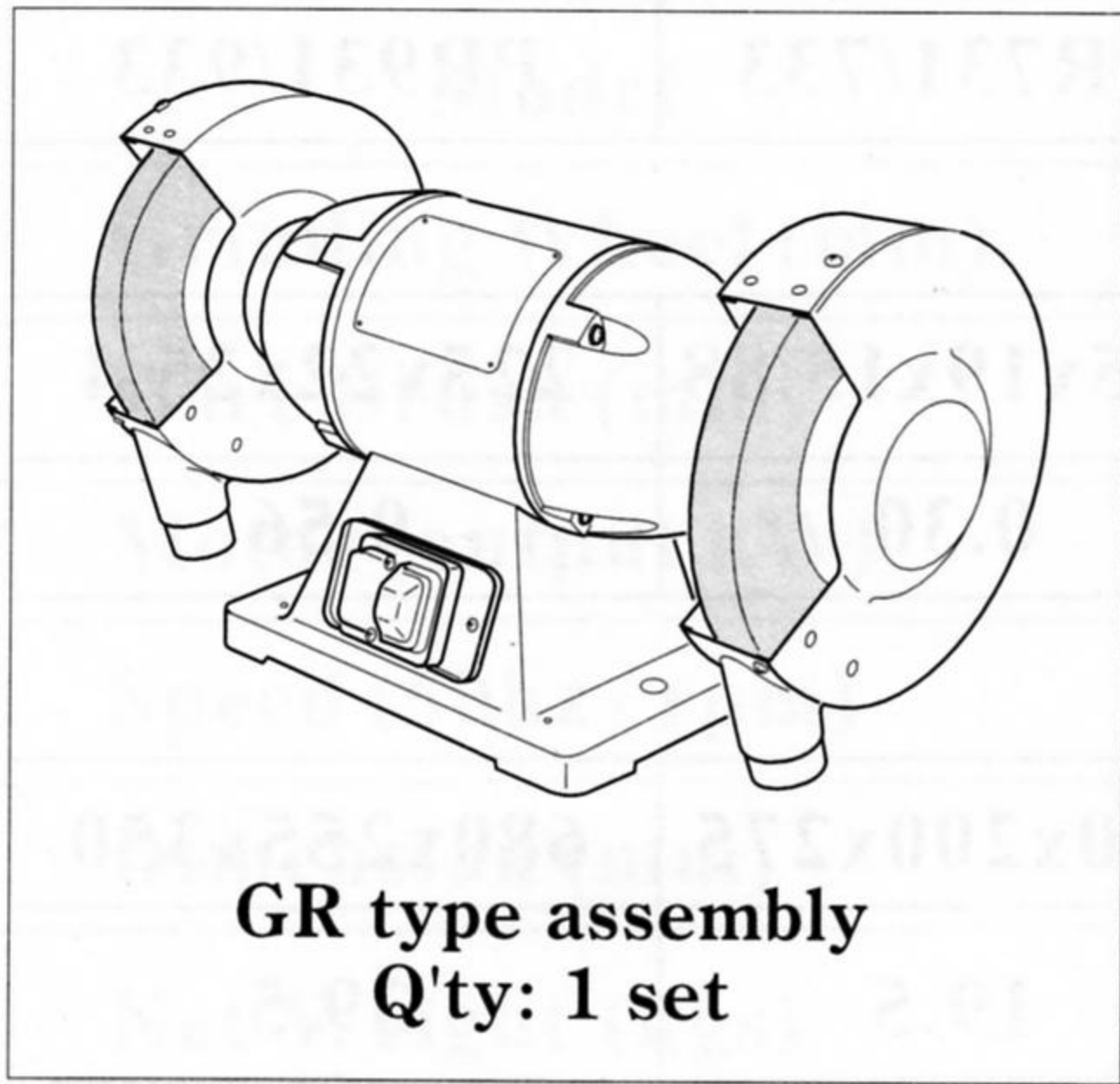

GR type assembly
Q'ty: 1 set

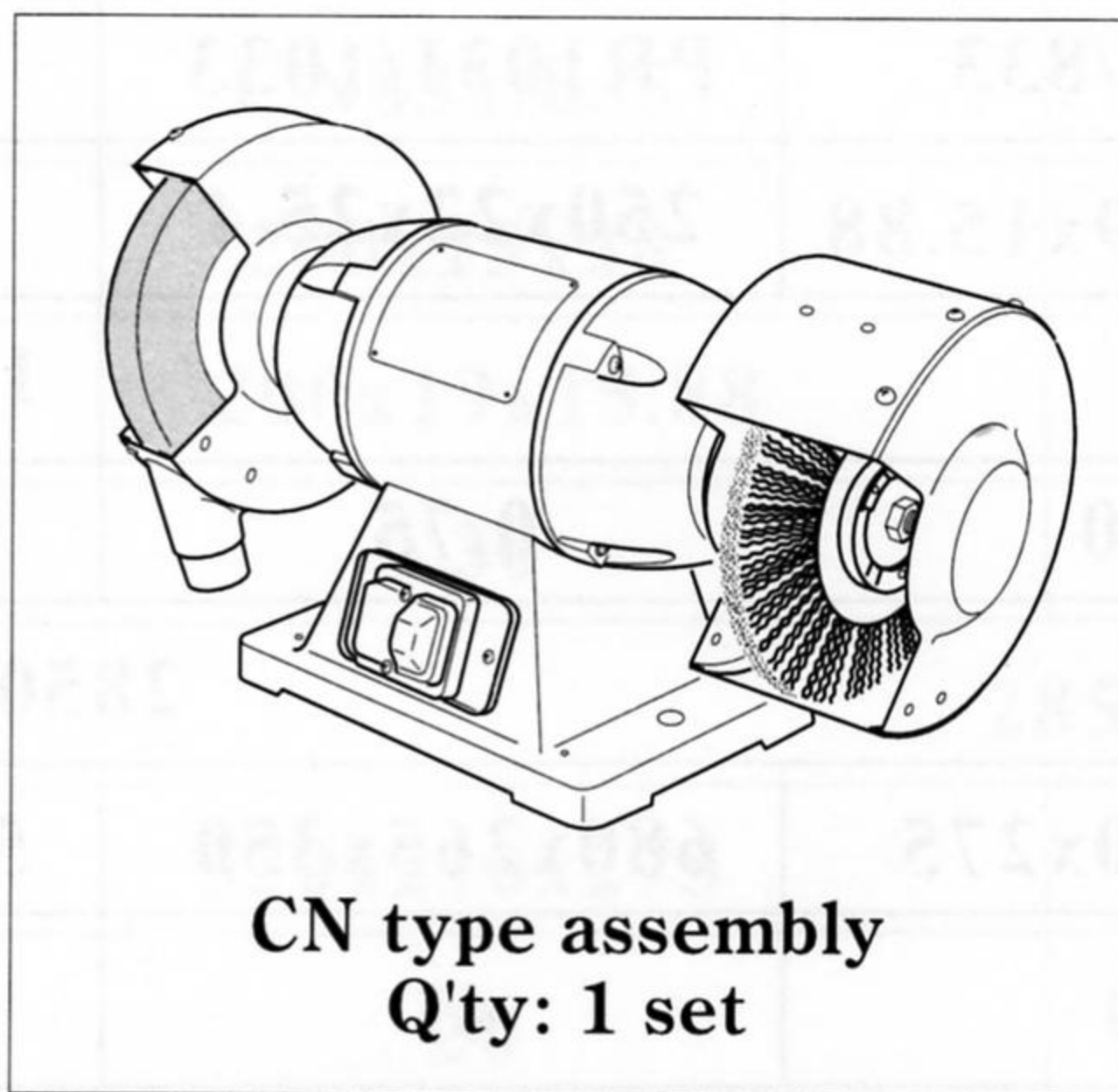

CN type assembly
Q'ty: 1 set

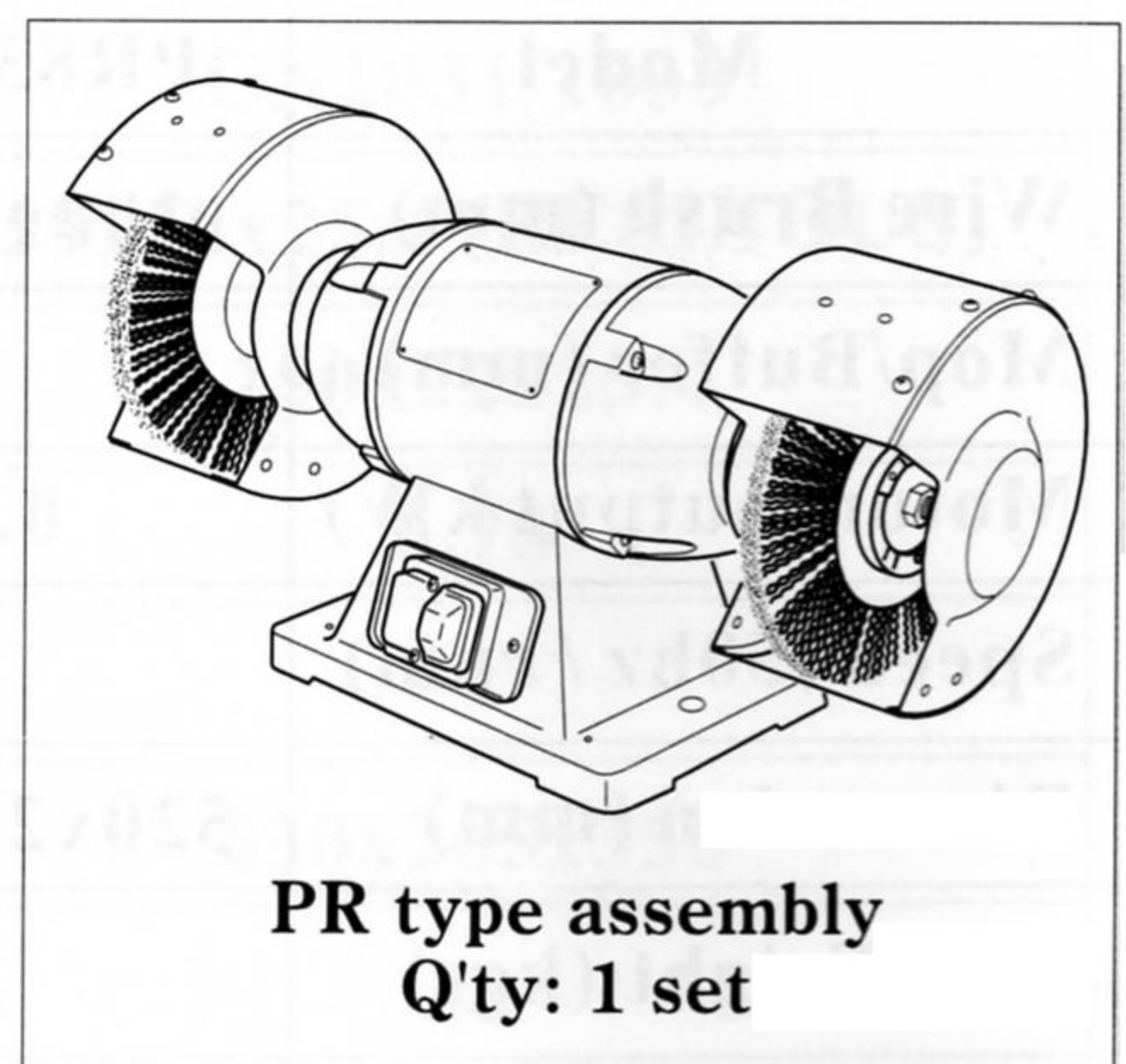

PR type assembly
Q'ty: 1 set

Bag 1 : Eyeshield

- GR : 2 sets GR type
- CN : 1 set GR type and 1 set PR type
- PR : 2 sets PR type

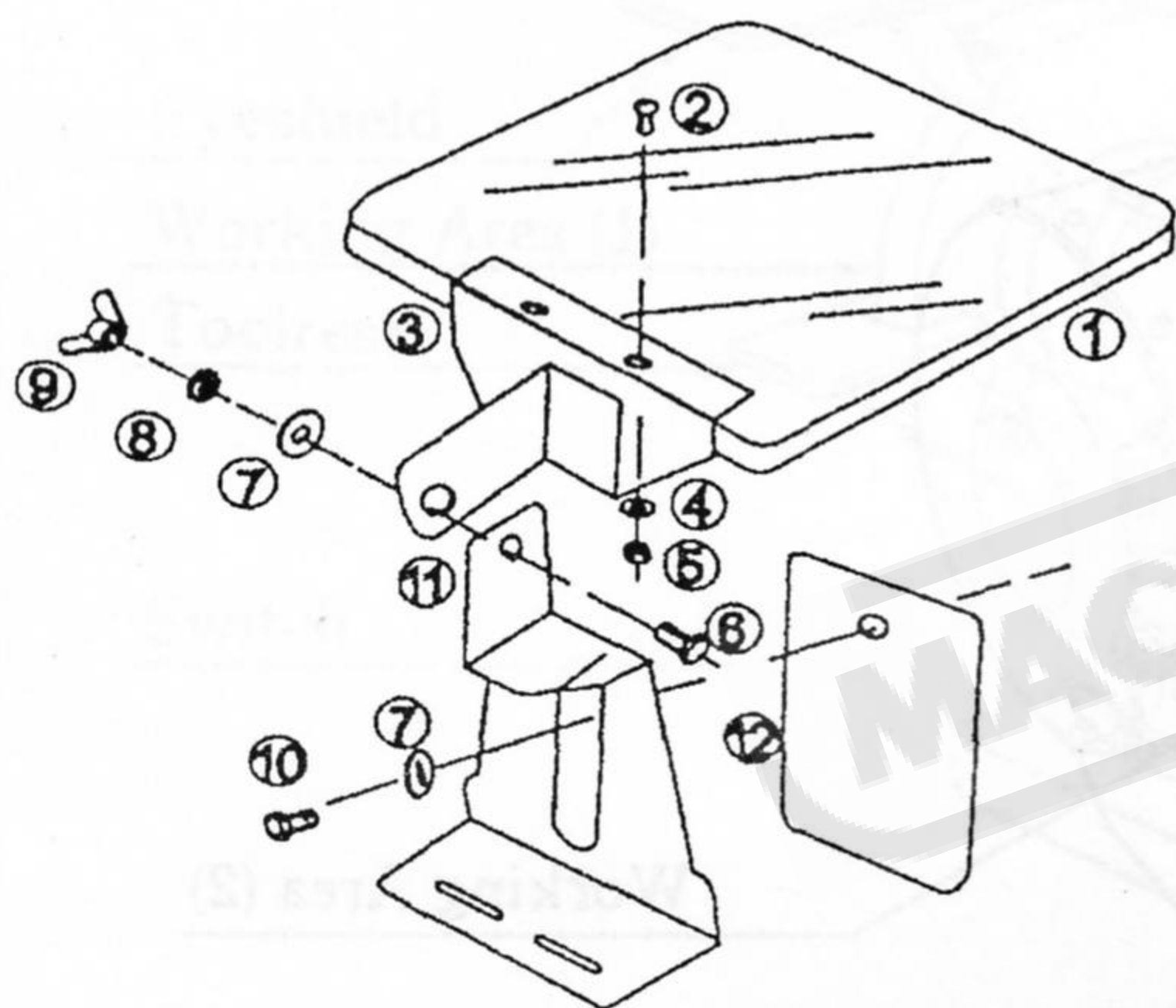

Parts ⑦ ⑩ & ⑫ for GR type only

Ref.No.	Parts Name	Q'ty	
		GR	PR
1	Eye Shield	1	1
2	Screw	1	1
3	Support Plate	1	1
4	Washer	2	2
5	Hex. Nut	2	2
6	Hex. Bolt	1	1
7	Washer	2	1
8	Spring Washer	1	1
9	Wing Nut	1	1
10	Screw	1	-
11	Bracket	1	1
12	Spark Arrestor	1	-

Bag 2 : Toolrest

- GR : 2 sets
- CN : 1 set
- PR : -

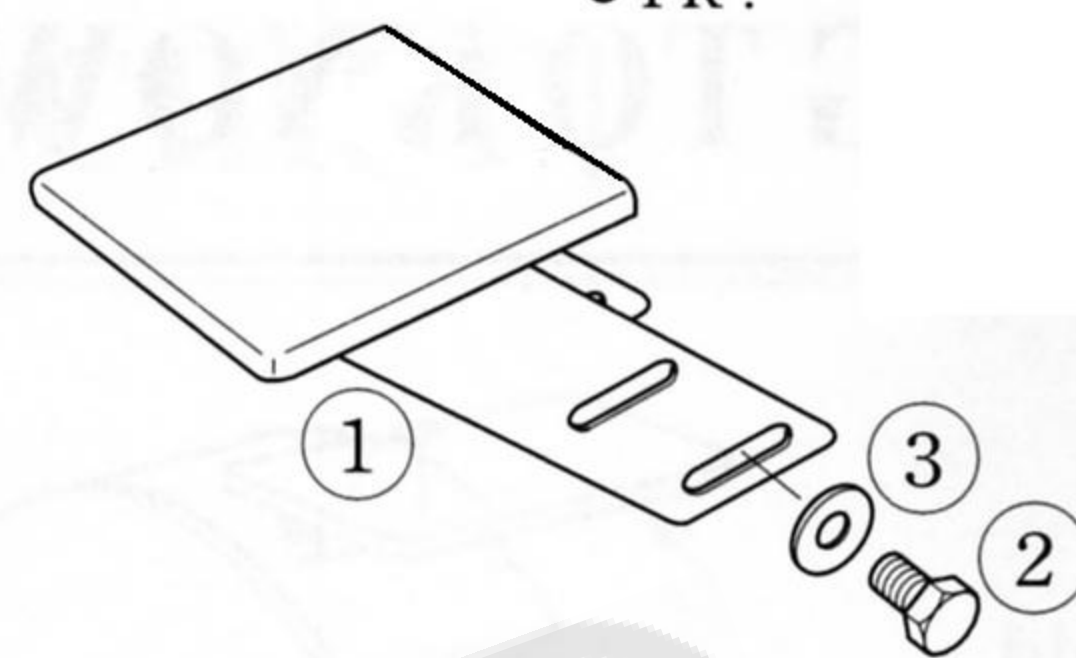

Ref No.	Parts Name	Q'ty
1	Toolrest	1
2	Hex Bolt	4
3	Washer	4

Bag 3 : Dust Collector

- GR : -
- CN : 1 set
- PR : 2 sets



Ref No.	Parts Name	Q'ty
1	Dust Collector	1
2	Hex Bolt	4
3	Washer	4
4	Chip Outlet	1
5	Screw	4
6	Spring Washer	4

[REPLACEMENT OF WHEEL]

1. Remove toolrest and eyeshield or dust collector unit from wheel cover by taking off bolts and screws.
2. Take off screws to allow removing wheel cover as figure.
3. Remove nut, disc washer or balancing flange and waste wheel.
4. Put new wheel and every parts back in reverse order. It's important to make a good adjustment of balancing before assembling wheel covers. This message could be learned
5. For your safety, check all screws and bolts. Make sure they are all well fixed before switch on.
6. The distance between wheel, spark arrestor and toolrest table should be always remained at about 2-3mm to get the better spark arresting effect and good grinding performance.
7. When this distance was changed due to the wearing of wheel, you need to do adjustment.

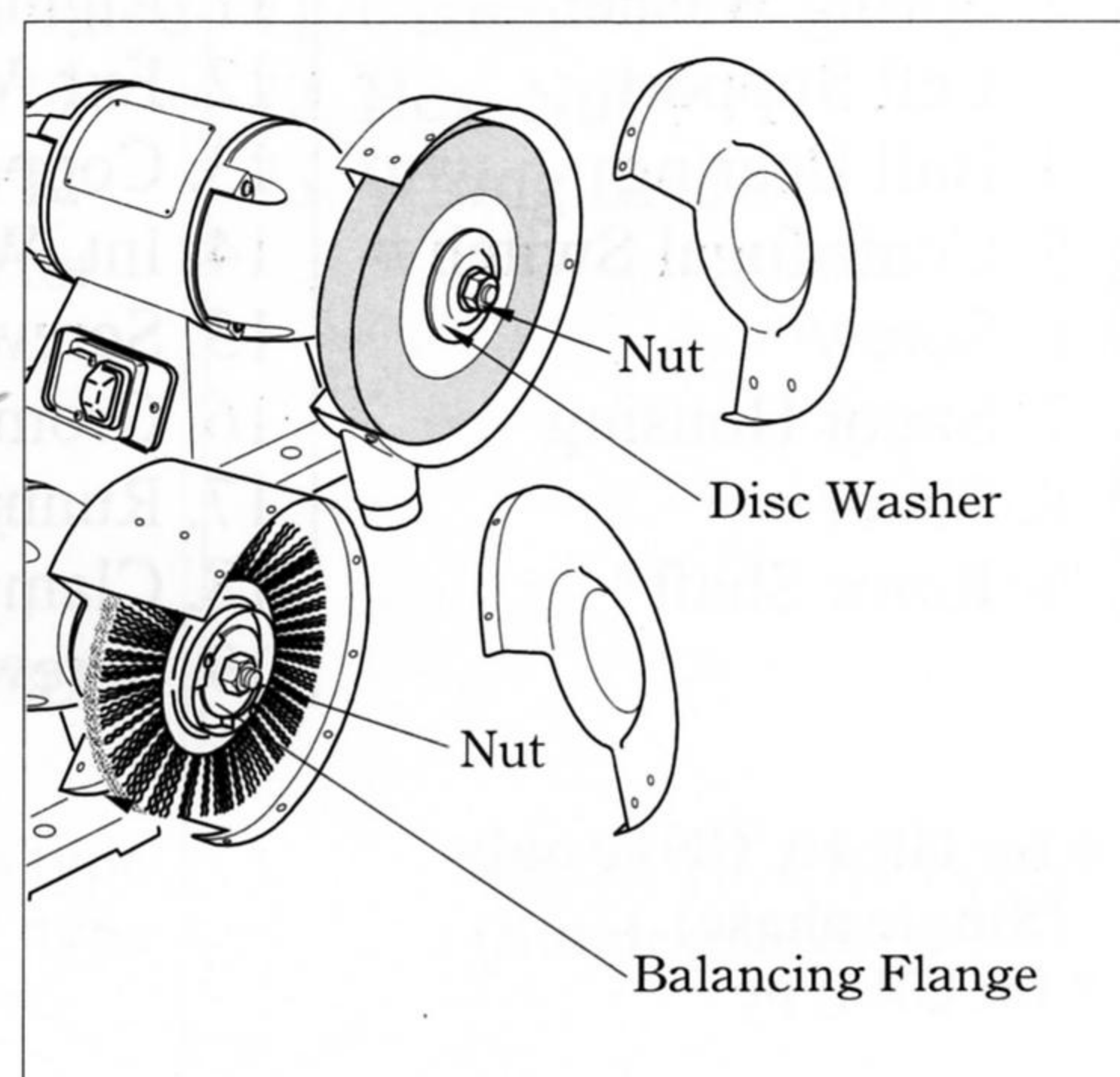

[ADJUSTMENT OF WHEEL BALANCE]

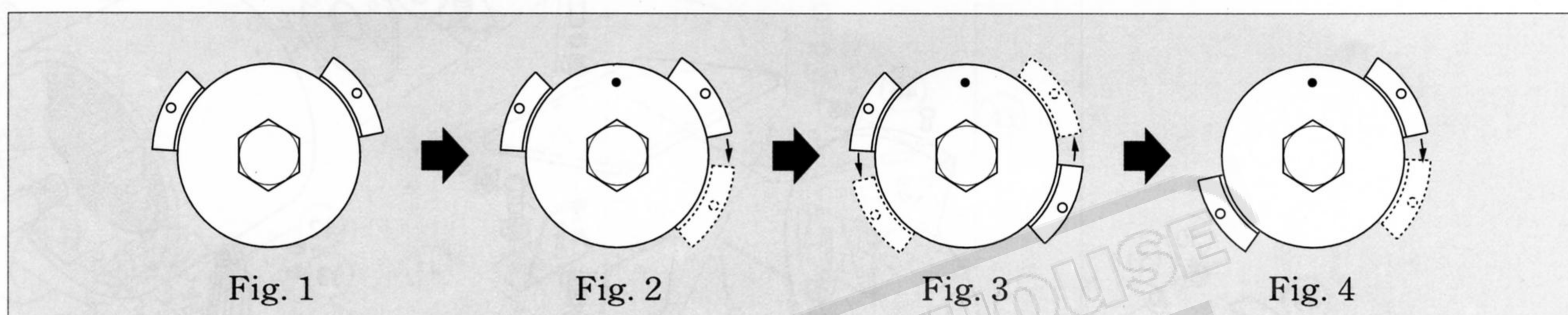

This job can be started when shaft nut of wheels were tightened.

The balancing adjustment was done through one particular parts of balancing blocks on balancing flange. It requires repeated testing by moving positions of two balancing blocks on balancing flange.

How to adjust

1. Put two balancing blocks in position showned in figure 1. Make first test run and check the balancing result.
2. Switch off if the balancing was no good. Start our first adjustment. Turn wheel to the original position as figure 1 by hand. Mark on wheel

as figure 2. Move the right hand balancing block clockwise to new position, and tighten it. Make the second test run and check again.

3. Switch off if it's still not satisfied. Return balancing block to original position. Move the left hand balancing block counterclockwise to new position as figure 3. Make test run again.
4. If this is still no good, stop machine and try new position as figure 4.
5. Please note that you should not adjust the much movement for balancing blocks in every step of mentioned above, and you will be easy to understand its characteristic and make the machine to be your hand.

Safety advice on the mounting of new grinding wheels

1. Before mounting the wheel, brush it clean and examine it for damage. The soundness of a new wheel can be further checked by suspending it vertically and tapping it with a light non-metallic implement; it should ring. Do not use it if it sounds dead (cracked).
2. Flange size is normally not smaller than 1/3 to of wheel diameter.
3. Do not force the wheel onto the machine or alter the centre hole diameter of the wheel.
4. Tighten the nut on the flanges only sufficiently to ensure that they drive the wheel. Hand pressure

on a standard spanner is enough; excessive force may damage the wheel.

5. Adjust the balancers of flanges.
6. Wheel of newly mounted must be tested on free run for at least one minute. Do not stand directly in front of the wheel while test run or when adjusting the balancers.
7. Ensure that the wheel guard is in position.
8. After finishing the mounting of new wheel, you may proceed to work, but please od not grinding at the side part of straight type wheels or with incompatible workpiece.

[EXPLODED VIEW]

- | | | | |
|-------------------------|-----------------------|--------------------|-------------------------|
| 1. Screw | 10. Fan | 20. Grinding Base | 30. Screw |
| 2. Spring Washer | 11. Right Support | 21. Screw | 31. NVR |
| 3. Left Support | 12. Ext. Washer | 22. Cable Strainer | 32. Overload Protector* |
| 4. Ball Bearing | 13. Copper Set | 23. Fixing Plate | 34. Spring Washer* |
| 5. Centrifugal Switch # | 14. Int. Washer | 24. Power Cord | 35. Hex. Nut* |
| 6. Screw | 15. Screw | 25. Washer | 36. Screw |
| 7. Stator Housing | 16. Grommet Rubber | 26. Screw | 37. Screw |
| 8. Stator | 17. Running Capacitor | 27. Base Plate | 38. Spring Washer |
| 9. Rotor Shaft* | 18. Clamp | 28. Pad | 39. Disc Washer |
| | 19. Screw | 29. Screw | |

for GR 10, CN10 only
(Single phase)
* for GR type

* for GR10, CN10 and PR 10 only

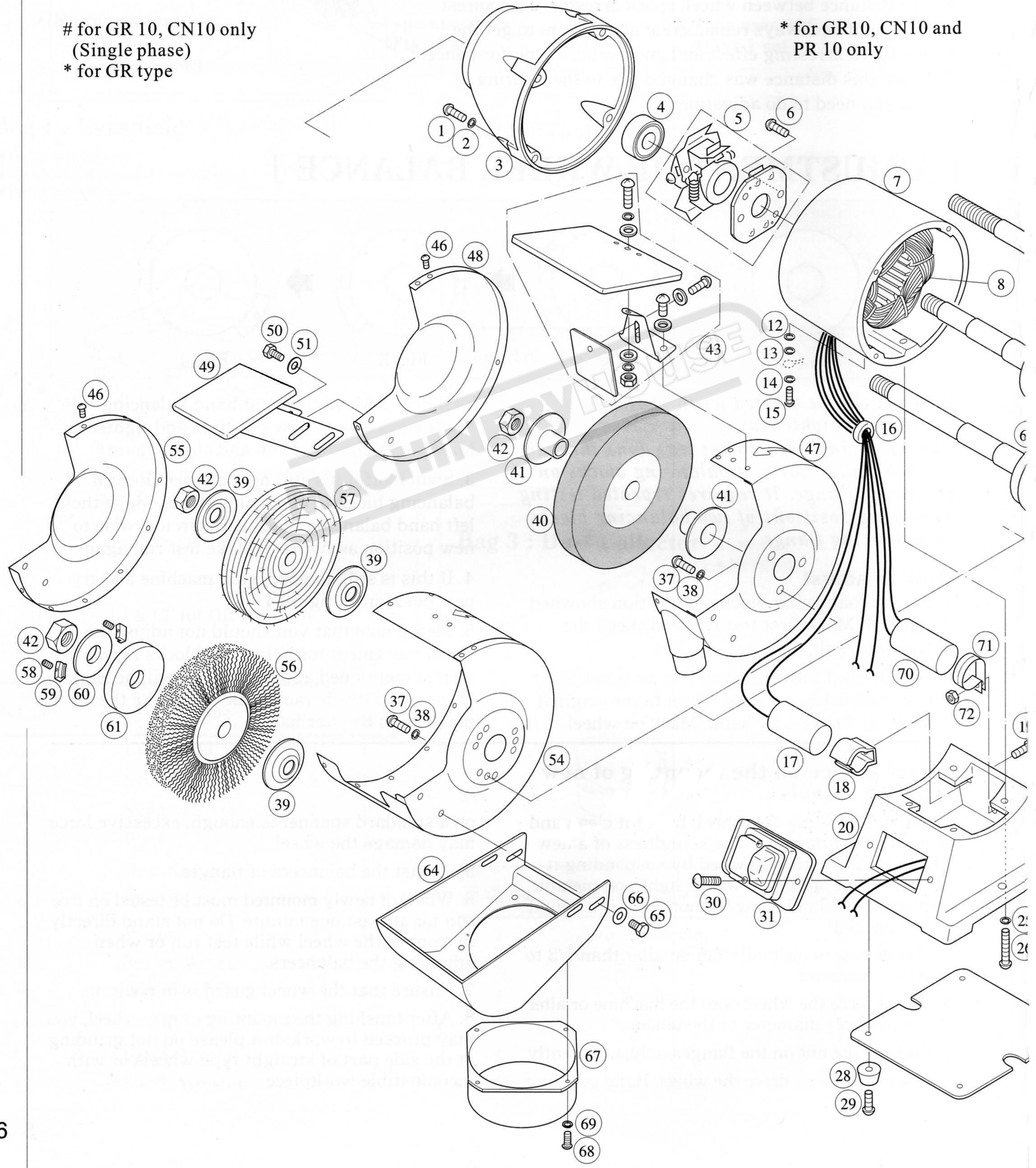

- 40. Grinding Wheel
- 41. Sleeve
- 42. Hex. Nut
- 43. Eyeshield Set
- 44. Right Int. Cover A
- 45. Right Wheel Cover A
- 46. Screw
- 47. Left Int. Cover A
- 48. Left Wheel Cover A
- 49. Toolrest

- 50. Hex. Bolt
- 51. Washer
- 52. Right Int. Cover B
- 53. Right Wheel Cover B
- 54. Left Int. Cover B
- 55. Left Wheel Cover B
- 56. Wire Brush
- 57. MOP/Buffer
- 58. Set Screw
- 59. Balance Block

- 60. Washer
- 61. Balancing Flange
- 62. Rotor Shaft*1
- 63. Rotor Shaft*2
- 64. Dust Collector
- 65. Hex. Bolt
- 66. Washer
- 67. Chip Outlet
- 68. Screw
- 69. Spring Washer

- 70. Starting Capacitor *
- 71. Clamp *
- 72. Hex. Nut *
- 73. Wiring Board

44+45+47+48 for GR type
 47+48+52+53 for CN type
 52+53+54+55 for PR type

*1 for CN type
 *2 for PR type

*for GR 10, CN10 only
 (Single phase)

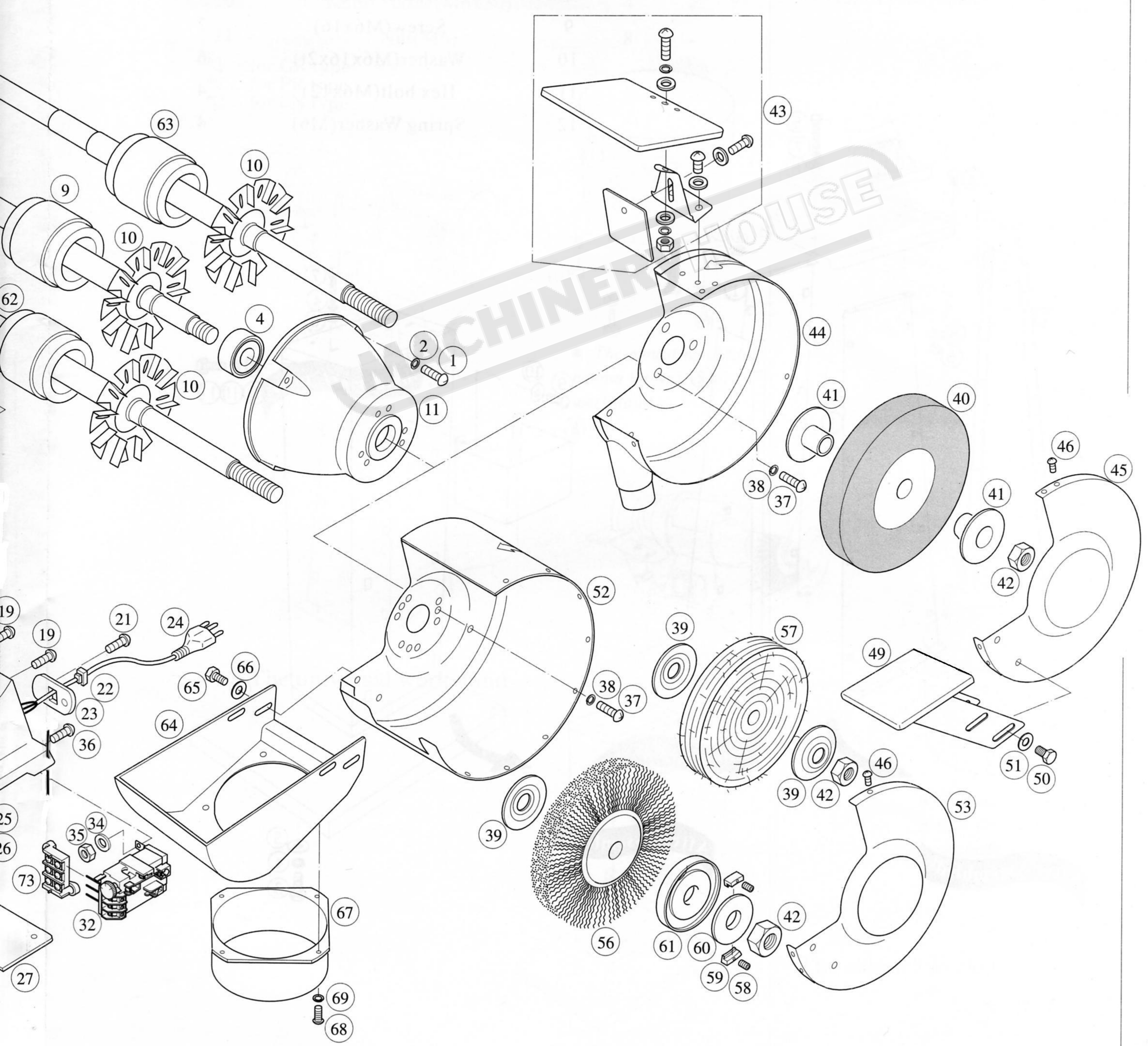

[ABOUT WORKSTAND] *Optional*

Unpacking and Checking List

• Universal Workstand

Ref No.	Parts Name /Description	Q'ty
1	Stand Leg(front & right)	2
2	Stand Leg(left & right)	2
3	Stand Top	1
4	Square Neck Bolt(5/16"-18NCx5/8")	4
5	Hex. Bolt(5/16"-18NCx1.5")	2
6	Hex. Nut(5/16")	6
7	Spring Washer(M8)	6
8	Washer(M8x18x2t)	8

• Cabinet Workstand

Ref No.	Parts Name /Description	Q'ty
1	Stand	1
2	Bottom Plate	1
3	Hex Bolt(M8x20t)	4
4	Spring Washer(M8)	6
5	Washer(M8x30x3t)	4
6	Washer(M8x18x2t)	2
7	Hex Bolt(M8x35L)	2
8	Cooler Boxer	1
9	Screw(M6x16)	2
10	Washer(M6x16x2t)	6
11	Hex bolt(M6x12)	4
12	Spring Washer(M6)	4

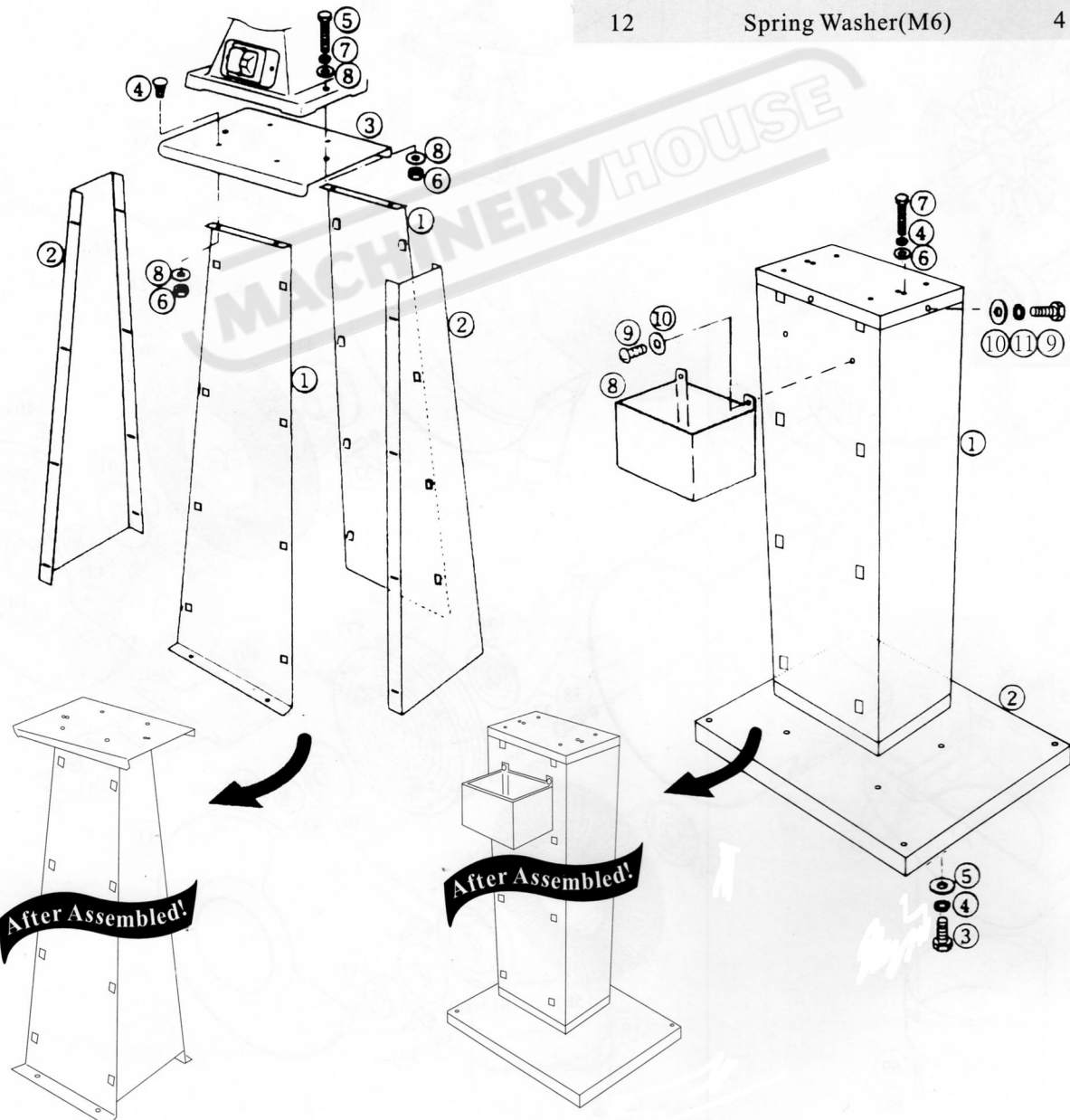

[DUST COLLECTION DEVICE] *Optional*

Unpacking and Checking List

Ref No.	Parts Name /Description	Q-ty	
		Universal type	Cabinet type
1	Dust Collection Tank	1	
2	Dust Collection Bag	1	
3	Tank Cover	1	
4	Chip Inlet(*1.5"/*2.4"/*3.4"-1.5")	2/2/1-1	
5	Hose(1.5"/4"/4"-1.5")	2/2/1-1	
6	Clamp(1.75"/4.5"/4.5"-1.75")	2/2/1-1	
7	Screw(M6x8)	8	
8	Screw(M6x16)	3	6
9	Washer(M6)	3	6
10	Knob Screw(M6x30)	4	-
11	Nut(M6)	8	-

*1 ... for GR type
 *2 ... for PR type
 *3 ... for CN type

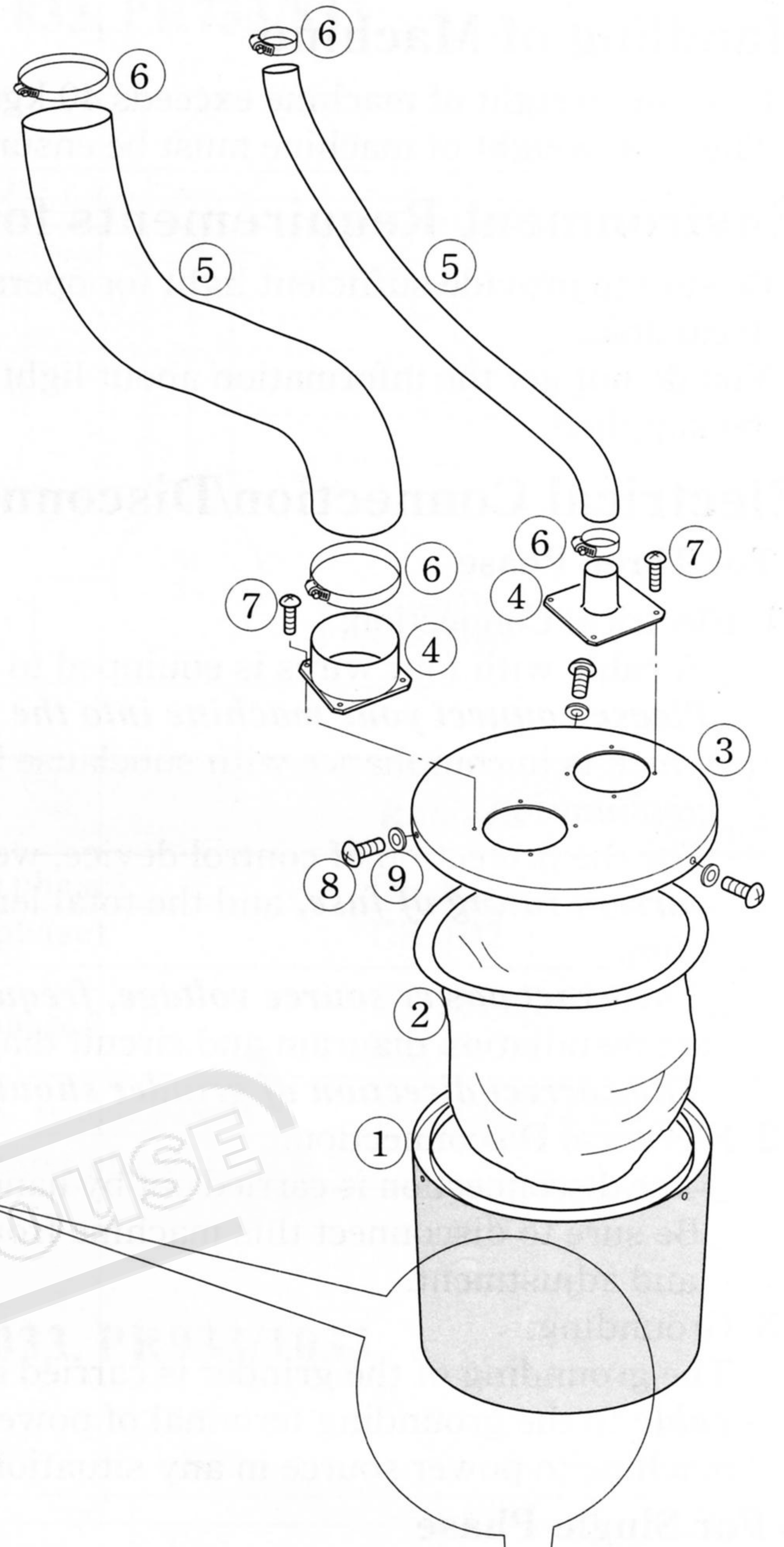

The universal workstand

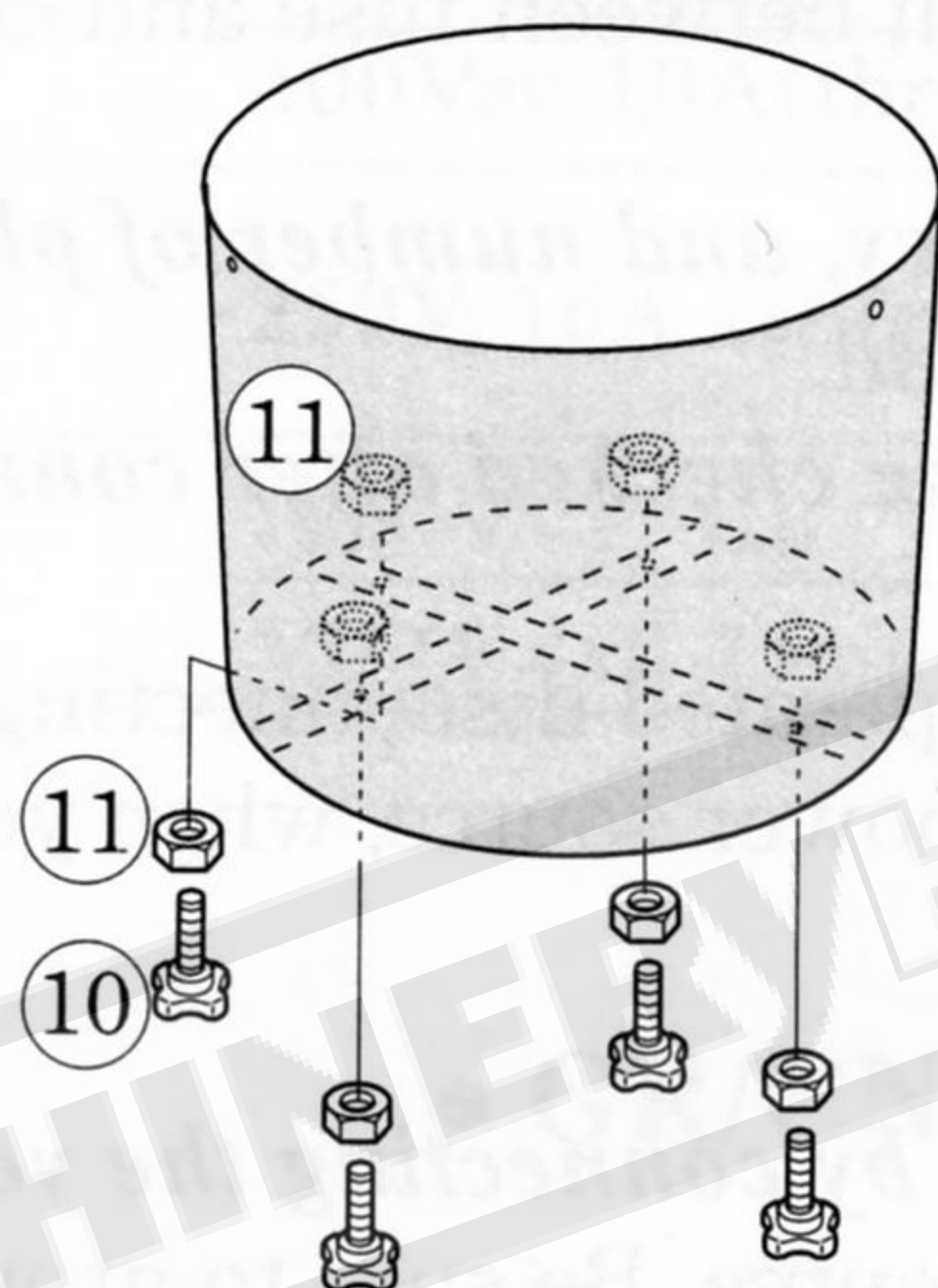

● The mounting of tank bottom for universal workstand.

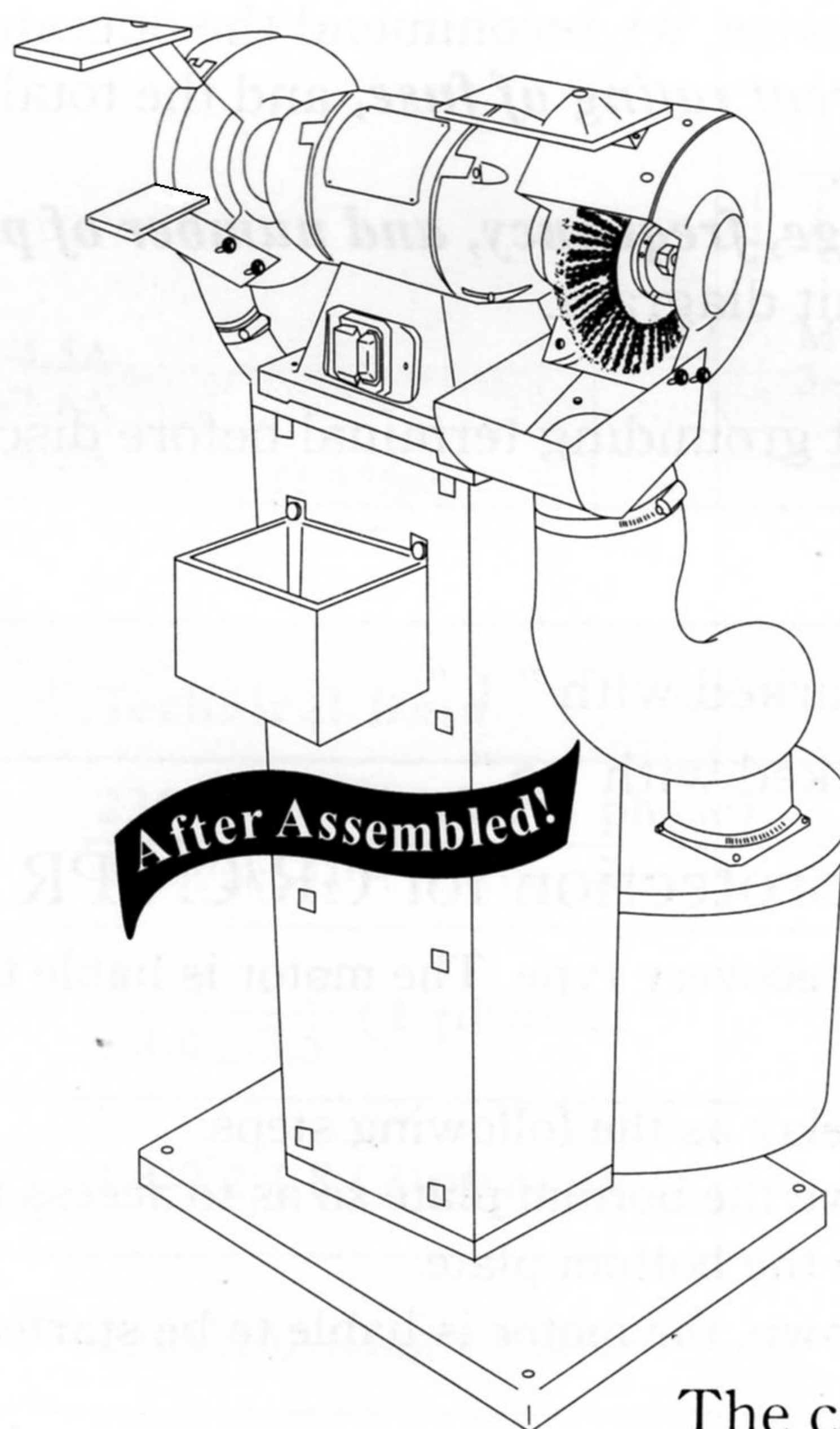

The cabinet workstand

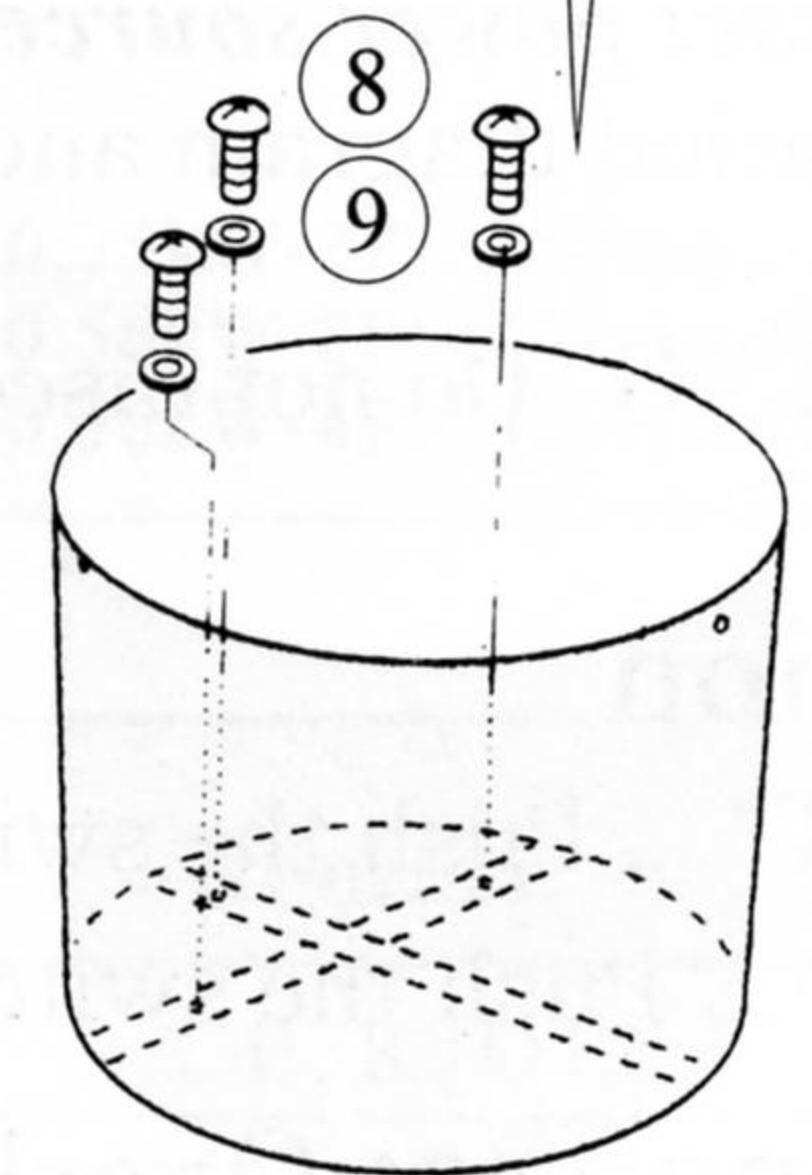

● The mounting of tank bottom for cabinet workstand.

[IMPORTANCE NOTICE FOR CE]

Handling of Machine

- If the net weight of machine exceeds 40 kgs, it is better to handle and transport with the help of lifting tools.
- The total weight of machine must be ensured before handling.

Environment Requirements for Installation

- Be sure to provide sufficient light for operation according to the codes or regulations published for local area.
- You do not get the information about lighting, a lighting intensity of 300 lux is the least value to be supplied.

Electrical Connection/Disconnection & Operation

• For Three Phase

1. Electrical Connection:

- _ A cable with four wires is equipped to connect your machine into the 3 phase power supply.
Please connect your machine into the power supply with hand-operated disconnection device, which is in compliance with subclause 5.3 of EN60204-1, such as no fuse breaker or plug/socket combination.
- _ For the protection of control device, we recommend the operator to supply **a fuse with 6 amp. current rating of fuse**, and the total length between fuse and connection terminal shall not exceed 1.5m.
- _ **The exact power source voltage, frequency, and number of phase** shall be checked according to the installation diagram and circuit diagram.
- _ **The correct direction of grinder should be checked after connection.**

2. Electrical Disconnection:

- _ The disconnection is carried out by hand-operated disconnecting device or plug/socket combination.
- _ Be sure to disconnect this machine from power source, when you want to stop the job, maintenance and adjustment.

3. Grounding:

- The grounding of the grinder is carried out **by connecting the yellow/green terminal of supply cable** to the grounding terminal of power source. Be sure to ground your machine before connecting machine to power source in any situation

• For Single Phase

1. The connection, disconnection and grounding is carried out **through the plug**, equipped on the grinder. For the safety reason, **do not change this plug into any other type in any situation.**
2. for the protection of control device, we recommend the operator to supply **a fuse with 6Amp. (GR/CN 10, PR9/10 with 10Amp.) current rating of fuse**, and the total length between fuse and connection terminal shall not exceed 1.5m.
3. **The exact power source voltage, frequency, and number of phase** shall be checked according to the installation diagram and circuit diagram.

WARNING Do not disconnect grounding terminal before disconnecting power source.

Operation

- "START" ... Push the switch marked with " I ".
- "STOP" ... Push the switch marked with " O ".

Maintenance: Overload protection for GR/CN/PR 10

- For three phase, it is an automatic recovery type. The motor is liable to be restarted if overload relay is cooled down automatically.
- For single phase, please reset the relay as the following steps:
 1. Lay down the machine and remove the bottom plate so as to access to the relay.
 2. Push the reset button and restore the bottom plate.
 3. Wait some minutes for cooling down, the motor is liable to be started.

[Electrical Circuit Diagram & Components Parts List]

• GR/CN 831, PR731

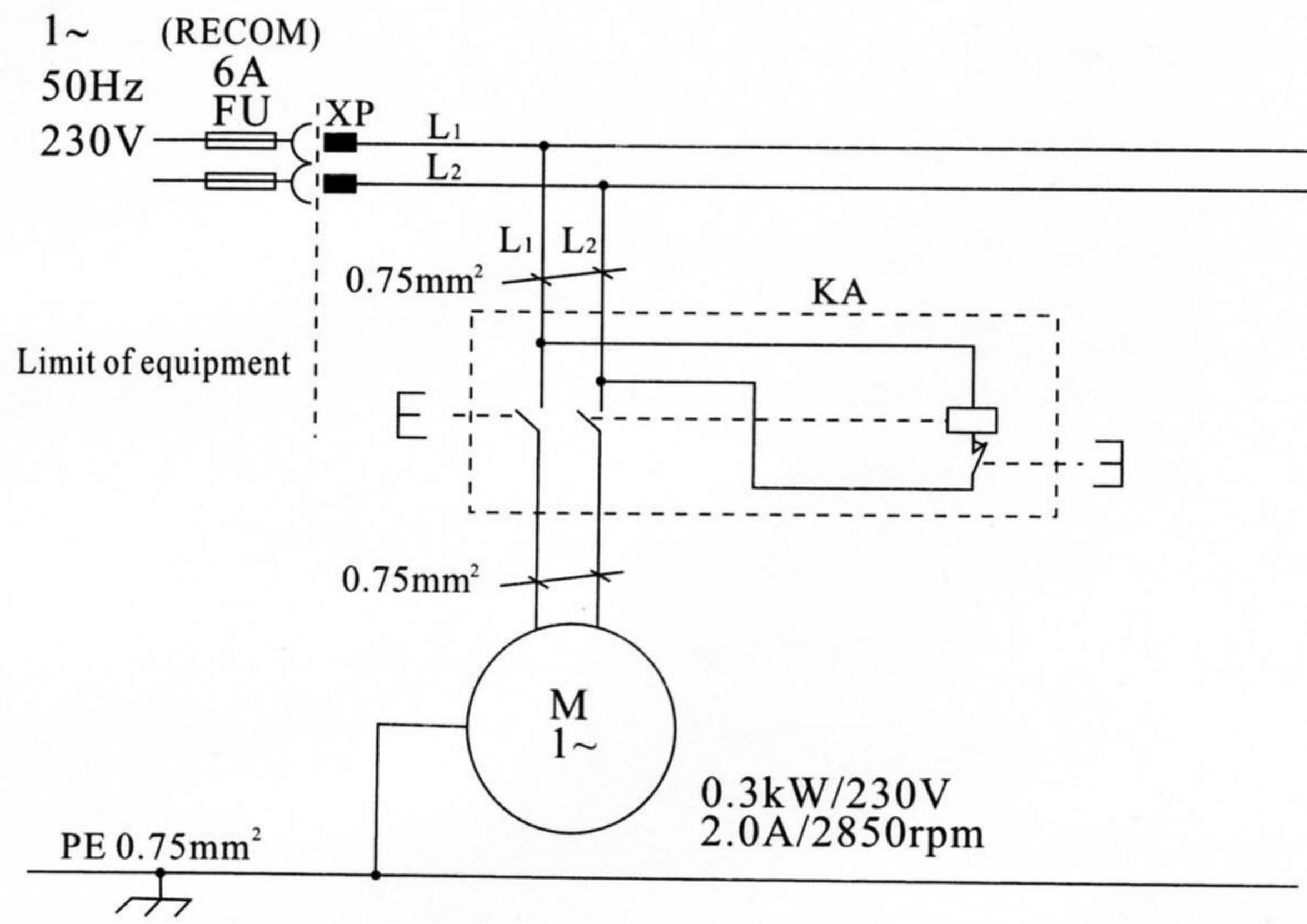

• GR/CN 833, PR733

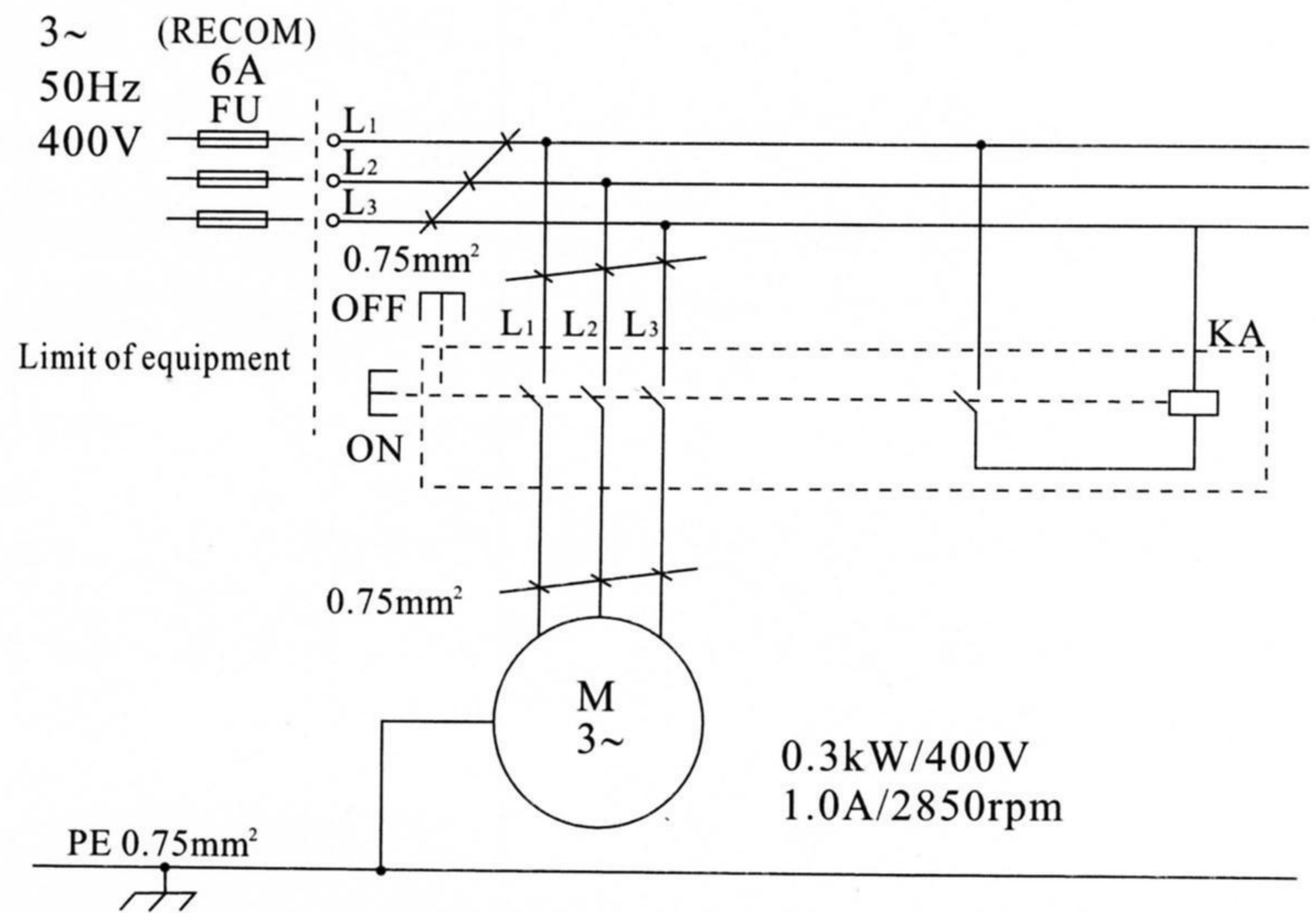

Item Designation	Description & Function	Technical Data	Remark
KA	Magnetic Contactor	230Vac, 10A (single phase) 400Vac, 10A (three phase)	CE, KJD12 CE, JD2
XP	Plug for Supply	250V, 16A (single phase)	CEBEC (D) FI (N) S (D) E KEMA (öve)
	Cable	H05-VVF 3x0.75mm ² (single phase) VCTF 4x0.75mm ² (three phase)	(D) E (S) KEMA (VDE0620)

• GR/CN 1031, PR931

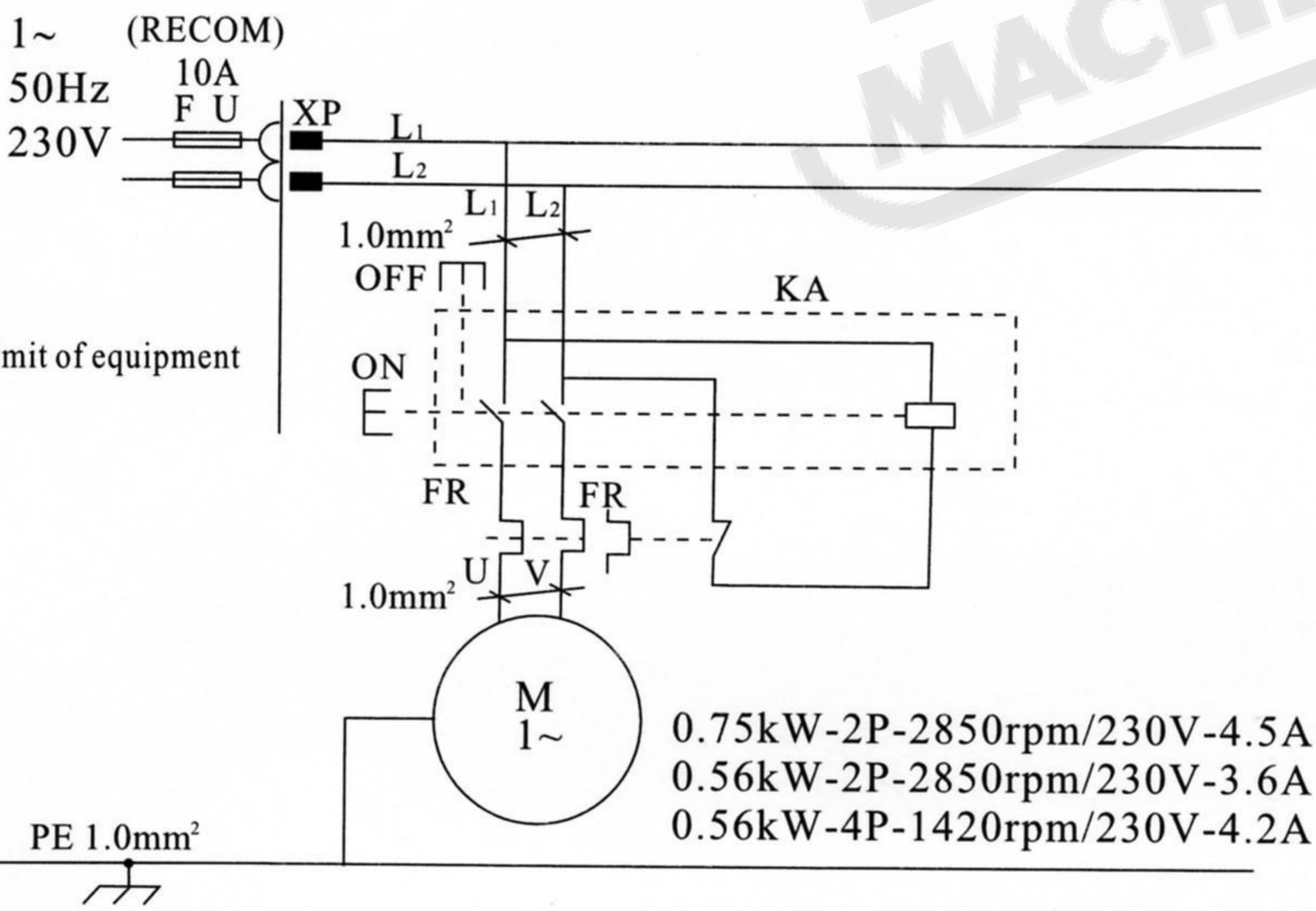

• GR/CN 1033, PR933

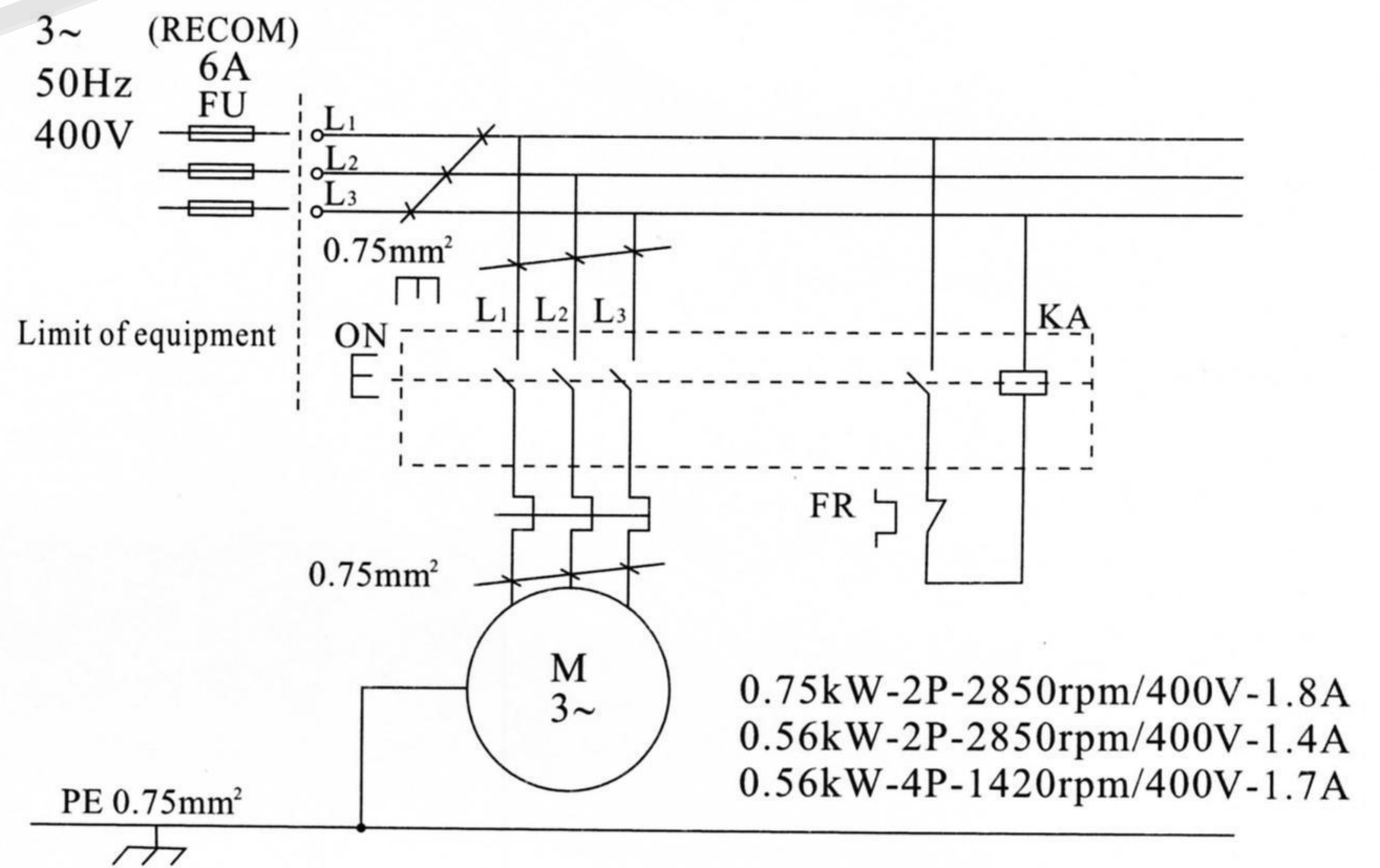

Item Designation	Description & Function	Technical Data	Remark
KA	Magnetic Contactor	230Vac, 10A (single phase) 400Vac, 10A (three phase)	CE, KJD12 CE, JD2
FR	Overload Protector	$\frac{0.75\text{kW} - 2\text{P}}{0.56\text{kW} - 2/4\text{P}}$ $\frac{4 - 6 / 5}{2.8 - 4.2/3.5}$ (1 phase)	CE, BTH
FR	Overload Protector	1.4-2.2/1.8 (3 phase)	CE, BTH
KP	Plug for Supply	250V, 16A (single phase)	CEBEC (D) FI (N) S (D) E KEMA (öve)
	Cable	H05-VVF 3x1.0mm ² (single phase) VCTF 4x0.75mm ² (three phase)	VDE